



SAFE.  
FAST.  
SMARTCHECK.



## STILL ACCURATE? CHECKED!

**SmartCheck-** In offering this new tester for torque wrenches and torque screwdrivers, STAHLWILLE is launching a versatile, easy-to-handle tool that will find a home in any workshop and service vehicle. Thanks to its compact dimensions, the ability to mount it horizontally or vertically, and the revolving display, it can be used virtually anywhere - and is easy to use, too. SmartCheck quickly provides information on whether or not a torque wrench is still within the prescribed tolerances or whether it requires adjustment.

### ROBUST.

The integrated visual and audible overload protection mechanism ensures the durability customers expect of STAHLWILLE.



### ACCURATE.

The display deviation value of a mere  $\pm 1\%$  guarantees the greatest possible measuring dependability.

### READY FOR WORK.

Thanks to the integrated transducer with a broad measuring range, work can start immediately.



## VERSATILE.

SmartCheck can be positioned almost anywhere. Whether horizontally or vertically - the well-thought-out fixing points, the compact construction and rotatable display make it easy to use.



## INDIVIDUAL.

Three operating modes (track, first peak, peak hold) and three measuring units (N·m, ft·lb, in·lb) can be selected. The target torque and tolerances can be individually set to evaluate the readings.

## MOBILE.

Ideal for use on the road if there are no power sockets available. Besides the usual operating mode using a mains adapter, this unit can be run on batteries (4 x AAA or 1 x 9 V block, adapter included).

## REVOLUTIONARY.

SmartCheck can easily be adjusted to suit the user's angle of sight. Not on the display but also the display mount and base body can be rotated through 180°.



## INTUITIVE OPERATION.

The unit is easy to use and has operator guidance to aid fast working, reliable results coupled with high levels of safety.



## RESILIENT.

The display and keypad are splash-proof, and the housing is made of impact-resistant plastic. Safe transport and storage is ensured by the sturdy transport box.



### Additional benefits:

- **For many torque ranges:** SmartCheck is available for these standard torque ranges: 1-10 N·m, 10-100 N·m, 40-400 N·m and 80-800 N·m.
- **For starters:** STAHLWILLE will soon be expanding the torque tester group of products. The focus will always be on versatility, performance and ease of use. Smart? And checked!

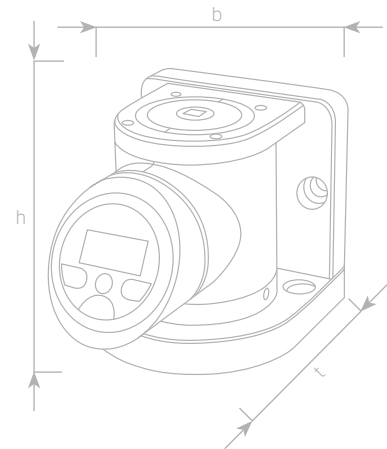

### SmartCheck torque tester

Code	No	N·m	ft·lb	in·lb	Ø "	b mm	h mm	t mm	Ø g
96 52 12 01*	SmartCheck 10S	1-10	0.74-7.4	8.9-88.5	1/4	120	124	167	5210
96 52 12 02	SmartCheck 10	1-10	0.74-7.4	8.9-88.5	1/4	120	124	167	5210
96 52 12 03	SmartCheck 100	10-100	7-74	89-885	3/8	120	124	167	5310
96 52 12 04	SmartCheck 400	40-400	30-295	354-3540	3/4	120	124	167	5690
96 52 12 05	SmartCheck 800	80-800	59-590	708-7081	3/4	120	124	167	5690

\* For checking torque screwdrivers



